

# HJ

## HARD JAWS (HJ-SERIES) FOR HYDRAULIC CHUCKS

### 油壓硬爪

#### 尺寸圖 » Dimensions

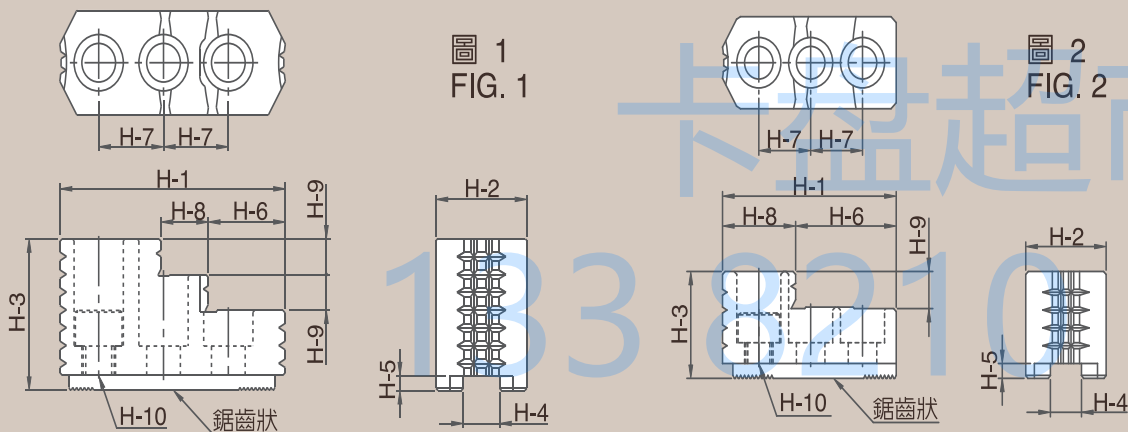

#### 規格表 » Specifications

單位/UNIT:mm

型式/規格 MODEL / SPEC.	H-1	H-2	H-3	H-4	H-5	H-6	H-7	H-8	H-9	H-10	鋸齒狀節距 Serration Pitch	淨重 Weight (kg)	參考圖 Reference Drawing
HJ-04	53	23	28	10	4	29	14	24	10	M8x1.25P	1.5 x 60°	0.4	圖-2 Fig.2
HJ-05	53	23	28	10	4	29	14	24	10	M8x1.25P	1.5 x 60°	0.4	圖-2 Fig.2
HJ-06	67	31	36	12	5	39	20	28	12	M10x1.5P	1.5 x 60°	0.95	圖-2 Fig.2
HJ-08	87	35	51	14	5	29.5	25	18	12	M12x1.75P	1.5 x 60°	1.9	圖-1 Fig.1
HJ-10	101	40	54	16	5	45.5	30	18	13	M12x1.75P	1.5 x 60°	2.8	圖-1 Fig.1
HJ-12	108	50	67	21(18)	4(5)	49	30	20	16	M16x2P(M14x2P)	1.5 x 60°	3.5	圖-1 Fig.1
HJ-15	143	62	86	22(25.5)	8(5)	55	43	38	20	M20x2.5P	1.5 x 60°	9.5	圖-1 Fig.1
HJ-18	143	62	86	22(25.5)	8(5)	55	43	38	20	M20x2.5P	1.5 x 60°	9.5	圖-1 Fig.1
HJ-21	159.5	80	90	25	9	97.5	50	62	40	M20x2.5P	3 x 60°	15.3	圖-2 Fig.2
HJ-24	159.5	80	90	25	9	97.5	50	62	40	M20x2.5P	3 x 60°	15.3	圖-2 Fig.2
HJ-32	159.5	80	90	25	9	97.5	50	62	40	M20x2.5P	3 x 60°	15.3	圖-2 Fig.2
HJ-40	159.5	80	90	25	9	97.5	50	62	40	M20x2.5P	3 x 60°	15.3	圖-2 Fig.2